

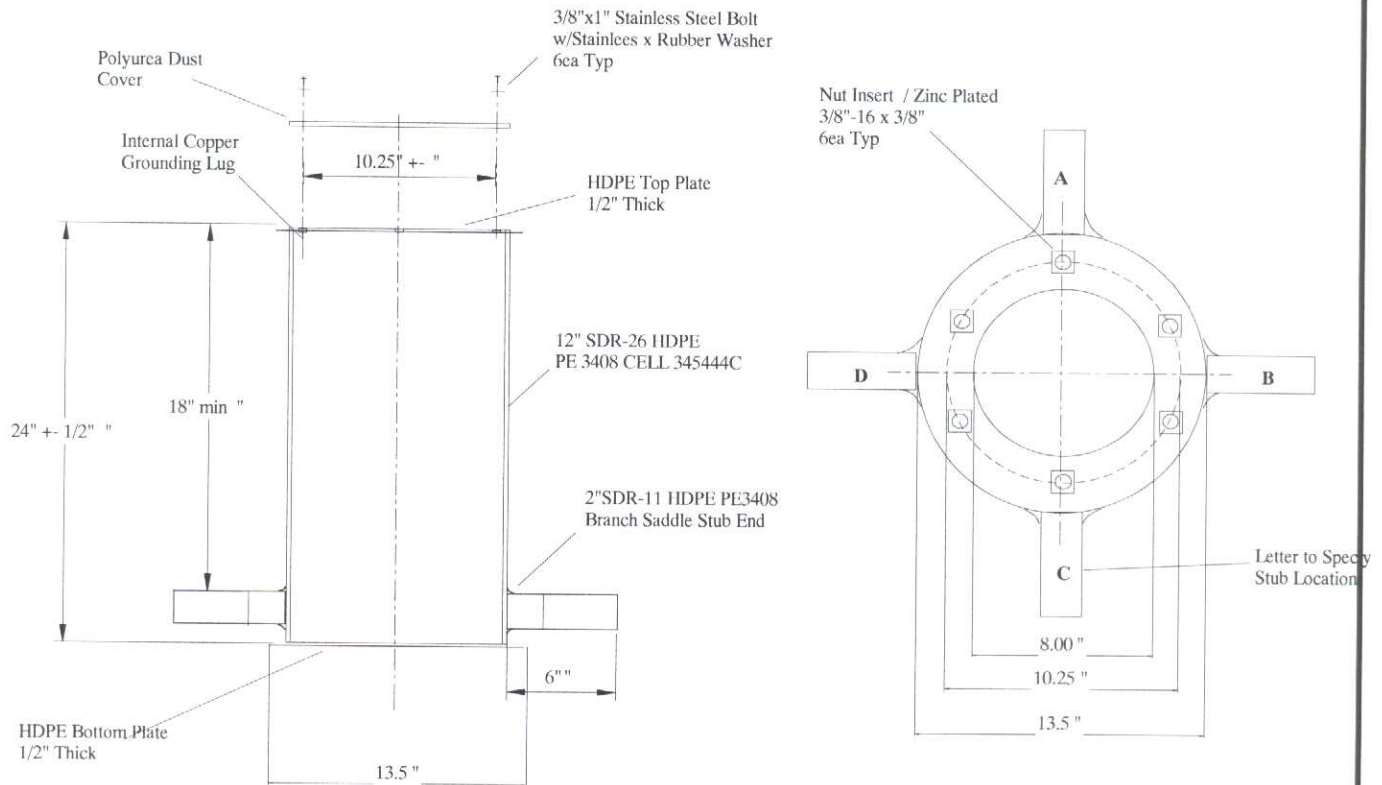

Arctic Insulation & Manufacturing

FAA Approved TYPE L-867 Runway Light Base High Density Polyethylene



Notes:

1. Manufactured by Arctic Insulation & Manufacturing in Big Lake, Alaska
2. All Joints to be fusion welded by machine pressure.
3. Optional thruway ground lug assembly on request.
4. Stub end locations specified by adding location ID to order. See top view.
5. FAA Third Party Certified