

Cable to Rail Web Grounding Connections

- Welded grounding connections to the web of 85 lb. to 140 lb. standard rails.
- If the ampacity requirement cannot be met with a single conductor listed, then two or more smaller conductors can be used.
- Molds listed are for concentric conductors.
- Mold frame includes adjusting screws to position the mold at the neutral axis of the rail.

Mold Information:

- Molds listed are for concentric stranded cable.
- Price Key is the **Bold Letter** in the Mold Part No.

Required Tools & Accessories:

- MH1 - Handle for "K" Price Key Molds
- RMFRMW105C - Rail Clamp
- Flint Igniter (FLTIG) included with MH1

Recommended Tools & Accessories:

- CCBRSH2 - Cable Cleaning Brush
- MCBRSH1 - Mold Cleaning Brush
- RASP - Rasp for cleaning rail

RMVH

(Rail Mold Vertical Web Horizontal Cable)

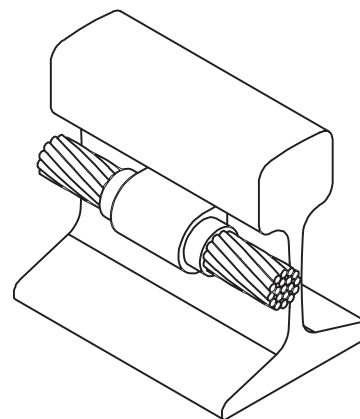

RMVH Connection Type

Size	Mold Part No.	Weld Metal	
		UltraShot	NUWTube
4 Concentric	RMVH4WEBK	US90R	NUWTUBE90R
2 Concentric	RMVH2WEBK	US90R	NUWTUBE90R
1 Concentric	RMVH1WEBK	US90R	NUWTUBE90R
1/0 Concentric	RMVH1/0WEBK	US115R	NUWTUBE115R
2/0 Concentric	RMVH2/0WEBK	US115R	NUWTUBE115R
4/0 Concentric	RMVH4/0WEBK	US150R	NUWTUBE150R

- Ultraweld exothermic materials meet requirements of AREMA 8.1.34.

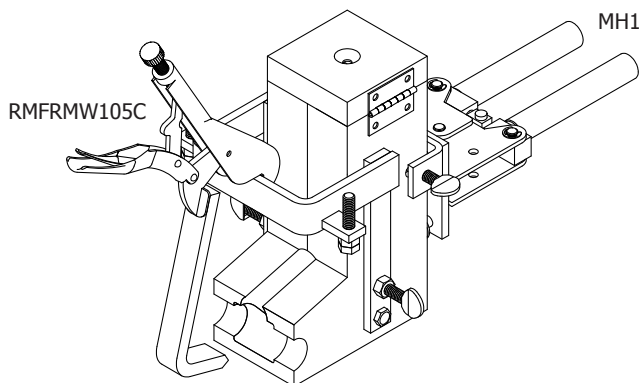

The adjusting screws on mold frame position conductor at neutral axis of rail where stresses are minimal.