

Cable to Steel Surface

Mold Information:

- **HU** mold cable is **off** the steel surface.
- **HT** mold cable is **on** the steel surface.
- **HT** molds used on conductors 1/0 and larger may need Mold Sealer (MLDSL, see page 320).
- Molds listed are for stranded cable. For solid conductor, add suffix "S" after conductor number. i.e. 4S = 4 AWG solid conductor.
- Molds with Price Key "**A**" SOLD WITH FRAME.
- If Frame not required, add suffix "-X" after the Mold Part No.
- Price Key is the **Bold Letter** in the Mold Part No.
- For **HU** mold Wear Plates, add suffix "WP" to the end of the Mold Part No. See page 315 for details.

Required Tools & Accessories:

- MH1 - Handle for "**B**" Price Key Molds
- MH2 - Handle for "**C**" Price Key Molds
- FLTIG - Flint Igniter when price key is "**A**"

Recommended Tools & Accessories:

- CCBRSH1 - Cable Cleaning Brush
- MCBRSH1 - Mold Cleaning Brush
- UMHDKIT - Hold Down Kit
- UMMHDA - Hold Down Kit when Price Key is "**A**"

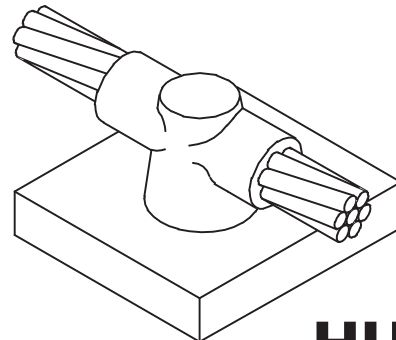

HU

(Horizontal Thru Cable to Horizontal Flat Steel Surface, OFF Surface)

HU Connection Type

Cable Size	Mold Part No.	Weld Metal	
		UltraShot	NUWTUBE
1/0	HU-1/0B	US90	NUWTUBE90
2/0	HU-2/0B	US115	NUWTUBE115
3/0	HU-3/0B	US115	NUWTUBE115
4/0	HU-4/0B	US150	NUWTUBE150
250 MCM	HU-25CMB	US150	NUWTUBE150
300 MCM	HU-3CMB	US200	NUWTUBE200
350 MCM	HU-35CMB	US250	NUWTUBE250
500 MCM	HU-5CMC	US300	2-NUWTUBE150

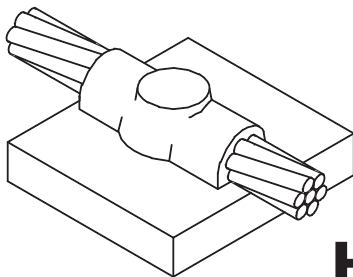

HT

(Horizontal Thru Cable to Horizontal Flat Steel Surface, ON Surface)

HT Connection Type

Cable Size	Mold Part No.	Weld Metal	
		UltraShot	NUWTUBE
#6	HT-6A	US45	NUWTUBE45
#4	HT-4A	US45	NUWTUBE45
#2 Sol	HT-2SA	US45	NUWTUBE45
#2	HT-2A	US45	NUWTUBE45
1/0	HT-1/0B	US90	NUWTUBE90
2/0	HT-2/0B	US115	NUWTUBE115
3/0	HT-3/0B	US115	NUWTUBE115
4/0	HT-4/0B	US150	NUWTUBE150
250 MCM	HT-25CMB	US150	NUWTUBE150
300 MCM	HT-3CMB	US200	NUWTUBE200
350 MCM	HT-35CMB	US200	NUWTUBE200
500 MCM	HT-5CMC	US300	2-NUWTUBE150

